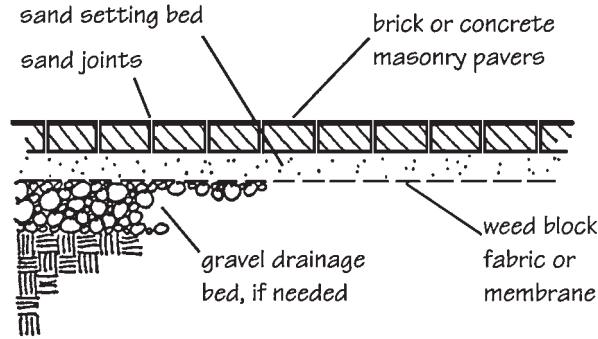
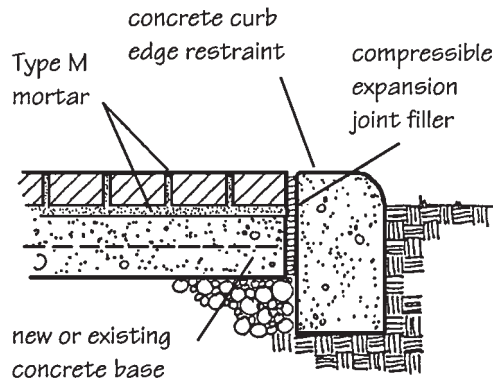

Figure 14-1 Concrete masonry grid paver installations. (From NCMA TEK Bulletin 91.)

direct contact with such contaminated materials may also be susceptible to efflorescence as a result of soluble salts leached to the surface (see Chapter 16). Gravel bases are suitable only for flexible paving, but can accommodate both pedestrian and light vehicular traffic. Ungraded gravel bases have better interlocking qualities, where graded gravel has a tendency to roll underfoot. Stone screenings compact better than pea gravel, but provide poorer subsur-



**Figure 14-2** Flexible masonry paving. (From Beall, *Masonry and Concrete for Residential Construction*, McGraw-Hill Complete Construction Series, 2001.)



**Figure 14-3** Rigid masonry paving. (From Beall, *Masonry and Concrete for Residential Construction*, McGraw-Hill Complete Construction Series, 2001.)

face drainage. Large gravel generally requires the use of heavy road construction equipment for proper preparation, whereas stone screenings of fine gradation lend themselves to compaction with hand tools. If the paving units are turned on edge for greater compressive depth, thin bases of fine screenings can accommodate the same light vehicular loads as thicker beds of coarse gravel. Aggregate bases range in thickness from 3 to 12 in., depending on the expected load and the paver thickness (see Fig. 14-4). Paving for vehicular traffic should be engineered for anticipated loads and the base material, thickness, compaction and optimum moisture content designed specifically for each site.

*Concrete bases* with either flexible or rigid paving can support heavy vehicular traffic. Existing concrete surfaces may be used, but major cracks must be properly filled and stabilized. If a mortar leveling bed is used over new or existing slabs, the surface should be raked or floated to facilitate good bond. If a non-cementitious leveling bed or cushion is used, the surface of new concrete need only be screeded.

*Asphalt bases* (new or used) can support flexible paving systems for heavy vehicular traffic. Mortar leveling beds can be used, but there will be little or no bond between the mortar and the asphalt. Mortar leveling beds should not be placed on hot or warm asphalt or flash setting of the mortar will occur. Any major defects in an existing asphalt pavement should be repaired before installing masonry pavers.